

Quick Start Guide

54-Port 10G/40G Fiber Ethernet Switch

AS5710-54X | AS5712-54X | AS5812-54X

1. Unpack the Switch and Check Contents

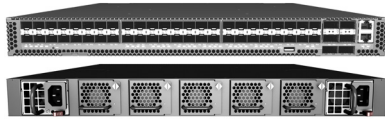

AS5710-54X,
AS5712-54X or
AS5812-54X

Rack Mounting Kit—2 front-post brackets, 2 rear-post brackets, 20 screws, and 2 ear-locking screws

Power Cord (included with AC PSUs only)

Ground Wire (included with DC PSUs only)

Console Cable—RJ-45 to DB-9

DC Power Cable (included with 48 VDC PSU only)

Documentation—*Quick Start Guide* (this document) and *Safety and Regulatory Information*



Warning: For a safe and reliable installation, use only the accessories and screws provided with the AS5710-54X, AS5712-54X, AS5812-54X. Use of other accessories and screws could result in damage to the unit. Any damages incurred by using unapproved accessories are not covered by the warranty.

Avertissement: Pour une installation sûre et fiable, utilisez uniquement les accessoires et les vis fournies avec le AS5710-54X, AS5712-54X, AS5812-54X. L'utilisation d'autres accessoires et vis pourrait endommager l'appareil. Les dommages causés par l'utilisation d'accessoires non approuvés ne sont pas couverts par la garantie.



Caution: The switch includes plug-in power supply (PSU) and fan tray modules that are installed into its chassis. All installed modules must have a matching airflow direction. That is, if the installed power modules have a front-to-back (F2B) airflow direction, all the installed fan tray modules must also have a F2B airflow direction.

Attention: Le commutateur comprend des modules d'alimentation et de bac de ventilateurs installés sur son châssis. Tous les modules installés doivent avoir une direction de circulation d'air correspondante. C'est-à-dire que tous les modules doivent avoir la même direction de circulation d'air : avant vers arrière (F2B), ou arrière vers avant (B2F).



Note: The switch has the Open Network Install Environment (ONIE) software installer pre-loaded on the switch, but no switch software image. Information about compatible switch software can be found at www.edge-core.com.



Note: The switch drawings in this document are for illustration only and may not match your particular switch model.

2. Attach the Brackets

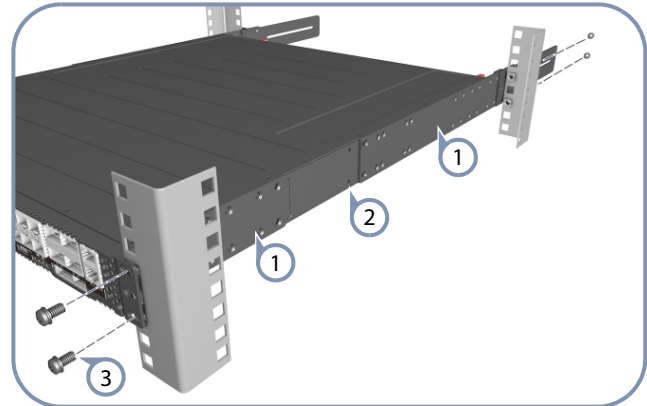

- 1 Attach each of the front- and rear-post brackets to the switch using four of the included bracket screws.
- 2 Use an additional two screws to secure each of the rear-post brackets at the mid-point on the sides of the switch.
- 3 Use the screws and cage nuts supplied with the rack to secure the switch in the rack.

3. Adjust Rear-Post Bracket Ears

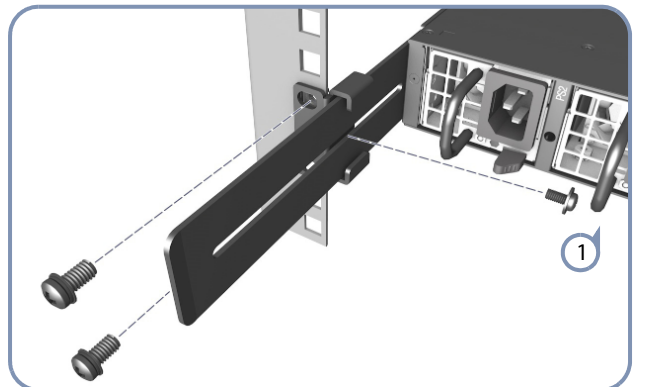

- 1 Lock the position of the rear-post bracket ears using the included position-locking screws. You can also adjust the rear-post bracket ears to fit different rack depths from 56 cm to 75 cm.

4. Ground the Switch

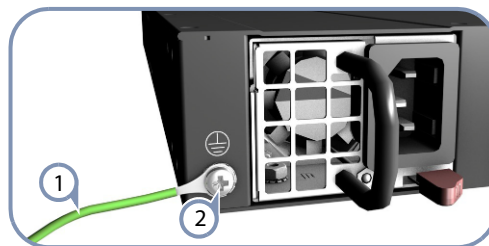

- 1 Ensure the rack is properly grounded and in compliance with ETSI ETS 300 253. Verify that there is a good electrical connection to the grounding point on the rack (no paint or isolating surface treatment).

- Attach the grounding wire #14 AWG to the grounding point on the switch rear panel. Then connect the other end of the wire to rack ground. For details on grounding the switch with a 12 VDC PSU in an Open Rack, refer to the Edgework ORSA-1U Open Rack Tray Set *Installation Guide*.



Caution: The earth connection must not be removed unless all supply connections have been disconnected.

Attention: Le raccordement à la terre ne doit pas être retiré sauf si toutes les connexions d'alimentation ont été débranchées.

5. Connect Power

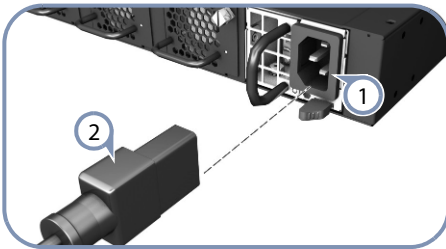

- Install one or two AC or DC power modules in the switch. The switch supports up to two PSUs that must have the same matching airflow direction as the installed fan tray.
- Connect an external AC or DC power source to the modules.

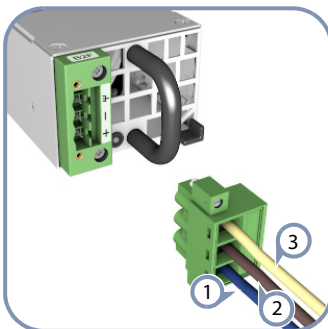

- 36 – 75 VDC Return (blue wire)
- 36 – -75 VDC (brown wire)

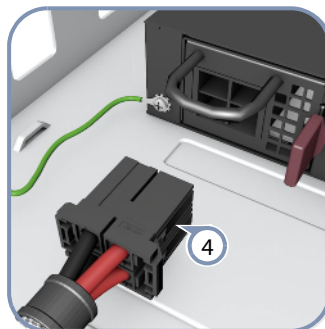

- Chassis Ground (yellow-green wire)
- Open Rack tray connector for 12 VDC PSU



Caution: Use a UL/IEC/EN 60950-1 certified power supply to connect to a DC converter, and a #14 AWG (for 36–75 VDC PSU) or #10 AWG (for 12 VDC PSU) wire to connect to a DC PSU.

Attention: Utilisez une alimentation certifiée UL/IEC/EN 60950-1 pour le connecter à un convertisseur CC et un câble AWG #14 (pour 36 VDC à 75 VDC) pour vous connecter à une alimentation CC.

6. Verify Switch Operation

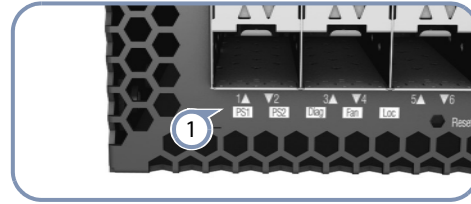

- Verify basic switch operation by checking the system LEDs. When operating normally, the PSU1/PSU2 and Fan LEDs should all be on green.

7. Perform Initial System Boot

- If the network operating system (NOS) installer is located on a network server, first connect the RJ-45 Management (Mgmt) port to the network using 100-ohm Category 5, 5e or better twisted-pair cable. (Not required if the NOS installer is located on attached storage.)
- Boot the switch. Wait for the ONIE software to locate and execute the NOS installer, and then wait for the installer to load the NOS software image. Subsequent switch boots will bypass ONIE and directly run the NOS software.



Note: For switches with ONIE software pre-loaded, refer to the network operating system (NOS) installer and NOS documentation for details on software options and set up for ONIE.

8. Connect Network Cables

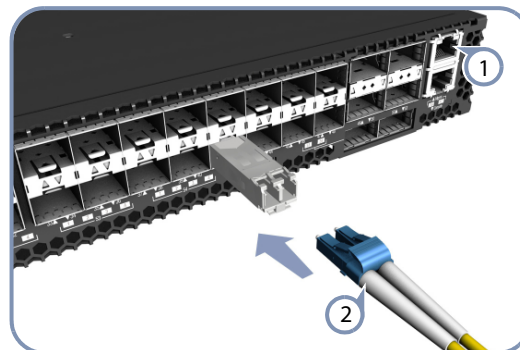

- For the RJ-45 Management port, connect 100-ohm Category 5, 5e or better twisted-pair cable.
- Connect DAC cables to the SFP+/QSFP+ slots. Or first install SFP+/QSFP+ transceivers and then connect fiber optic cabling to the transceiver ports.

The following transceivers are supported:

- ◆ 40GBASE-CR4
- ◆ 40GBASE-SR4
- ◆ 10GBASE-CR
- ◆ 10GBASE-SR (ET5402-SR)
- ◆ 1000BASE-SX (ET4201-SX)
- ◆ 1000BASE-LX (ET4201-LX)



Note: As connections are made, check the port status LEDs to be sure the links are valid.

9. View the Product Label

(For AS5712-54X/AS5812-54X only)

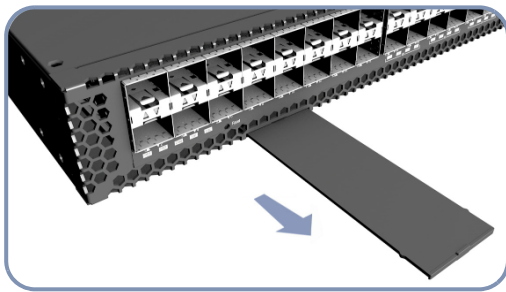

- 1 The switch product label is located below SFP+ ports 7–12 on left side of the front panel. Pull the label out to view the product information.

Hardware Specifications

Switch Chassis

Size (WxDxH)	438.4 x 473 x 43.4 mm (17.26 x 18.62 x 1.71 inches)
Weight	AS5710-54X / AS5712-54X: 8.87 kg (19.56 lb), with two installed PSUs AS5812-54X: 8.95 kg (19.73 lb), with two installed PSUs
Temperature	Operating: 0° C to 40° C (32° F to 104° F) Storage: -40° C to 70° C (-40° F to 158° F)
Humidity	Operating: 5% to 95% (non-condensing)
Power Consumption	282 Watts maximum

AC PSU

Power Rating	100–240 VAC, 50-60 Hz, 400 Watts
AC Input	100–240 VAC, 50-60 Hz, 6–3 A
DC Output	5 VSB @ 3 A, 12 VDC @ 33 A

48 VDC PSU

Power Rating	48 VDC, 400 Watts
DC Input	36–75 VDC, 16 A maximum
DC Output	5 VDC @ 0.5 A, 12 VDC @ 33 A

12 VDC PSU (PSU-12V-650)

DC Input	12 VDC (from Open Rack busbar)
----------	--------------------------------

Regulatory Compliances

Emissions	EN 55032:2012+AC:2013, Class A AS/NZS CISPR 32:2013, Class A CISPR 32:2012, Class A EN 61000-3-2:2014, Class A EN 61000-3-3:2013 FCC Class A VCCI Class A CE Mark KCC (AS5710-54X/AS5712-54X only) CCC GB 9254-2008, Class A BSMI EMI Standard CNS 13438:2006 (AS5712-54X/ AS5812-54X only)
Immunity	EN 55024:2010+A1:2015 IEC 61000-4-2:2008 ED. 2.0 IEC 61000-4-3:2010 ED. 3.2 IEC 61000-4-4:2012 ED. 3.0 IEC 61000-4-5:2014 ED. 2.0 IEC 61000-4-6:2013 ED. 4.0 IEC 61000-4-8:2009 ED. 2.0 IEC 61000-4-11:2004 ED. 2.0
Safety	UL (CAN/CSA C22.2 No. 60950-1 & UL60950-1) CB (IEC/EN60950-1) CCC GB4943.1-2011 BSMI Safety Standard CNS14336-1
Taiwan RoHS	CNS 15663

快速入门指南

54 端口 10G/40G 以太网交换机

AS5710-54X | AS5712-54X | AS5812-54X

1. 打开交换机的包装并检查内装物

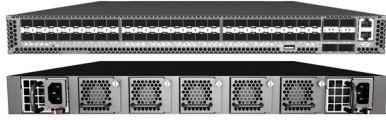



AS5710-54X,
AS5712-54X 或
AS5812-54X

 前柱支架 x2, 带可调节吊耳的后柱支架 x2, 支架螺丝 x20, 后支架吊耳位置 - 锁定螺丝 x2

 电源线 (仅随 AC PSU 附带)

 接地线 (仅随 DC PSU 附带)

 控制台线 — RJ-45 转 DB-9

 DC 电源线 (仅随 48 VDC PSU 附带)

 文档 — 快速入门指南 (本文档) 以及安全和管制信息

 **警告:** 为了可以更安全的使用与安装机台, 请务必使用 AS5710-54X, AS5712-54X, AS5812-54X 随货附赠的配件, 避免导致设备损坏或其他风险产生。使用未经批准的配件造成的任何损坏, 均不在保修范围内。

 **警告:** 本交换机的机箱中安装有插入式电源 (PSU) 和风扇架模块。所有后部安装模块都必须具有匹配的气流方向。即, 如果安装的电源模块有从前到后 (F2B) 的气流通过, 则所有安装的风扇架模块也必须有 F2B 气流通过。

 **注意:** 此交换机预装了 Open Network Installer Environment (ONIE) 软件, 但没有预装交换机软件映像。有关其他交换机相容软件, 请参考 www.edge-core.com 网站说明。

 **注意:** 本文档中的交换机图片仅用于举例说明, 不一定与您的交换机实际外观完全一致。

2. 安装交换机

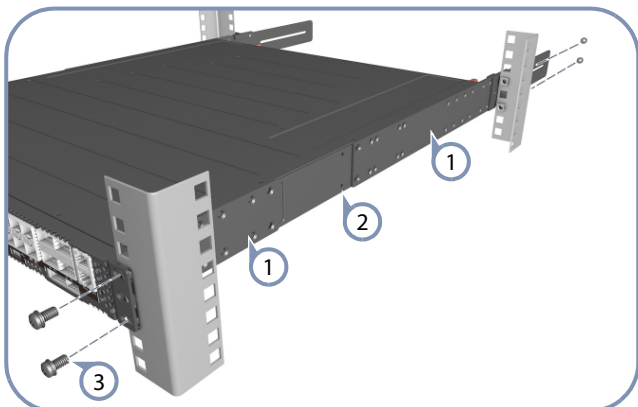



 1 使用四个随附的支架螺丝将各个前柱和后柱支架安装到交换机。

 2 使用另外两个螺丝将每个后柱支架固定到交换机侧面上的中间点。

 3 使用机架随附的螺丝和卡式螺母将交换机固定到支架上。

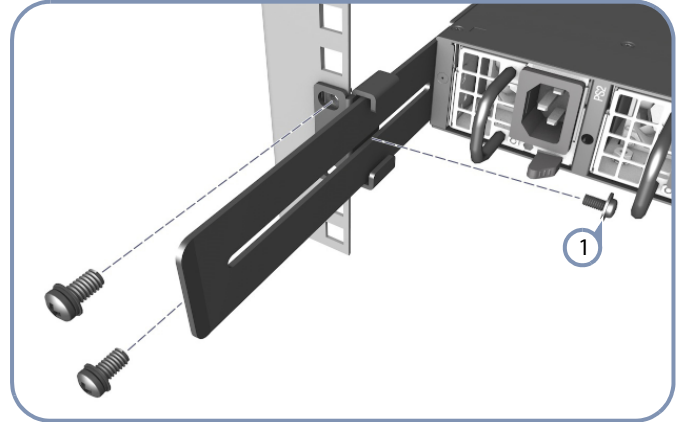
3. 调整后柱支架吊耳



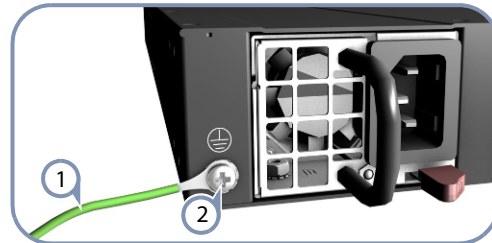

 1 使用随附的定位螺丝固定后柱支架吊耳的位置。此外, 还可以调整后柱支架吊耳以适合不同的机架深度, 范围是 56 cm 到 75 cm。

4. 对交换机实施接地



 1 请确保对机架正确实施接地, 并确保符合 ETSI ETS 300 253。请确认机架上的接地点的电气导通状态良好 (确保没有油漆或绝缘表面处理)。

 2 将 14 号的 AWG 接地线连接至交换机背面面板上的接地点上。然后将接地线的另一端连接至机架的接地。关于如何连接 12 VDC PSUs 至开放式机架连接器, 请参阅 Edgecore ORSA-1U Open Rack Tray Set 安装手册。

 **警告:** 在断开所有电源连接前, 切勿断开接地。

5. 连接电源

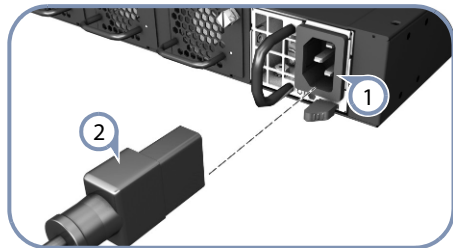

- ① 在交换机上安装 1 个或 2 个 AC 或 DC 电源模块。本交换机可使用最多 2 个 PSU，且 PSU 的气流方向必须与安装的风扇框相同。
- ② 将外部 AC 或 DC 电源连接至模块。

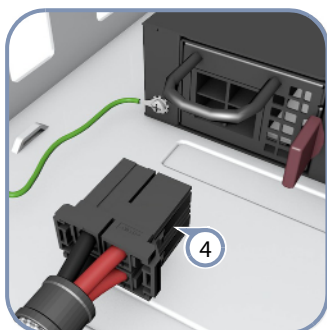
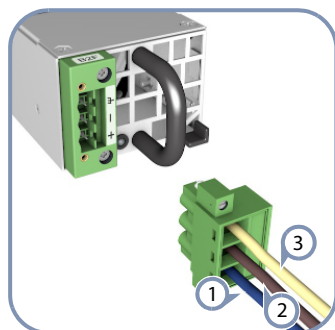

- ① 36 - 75 VDC Return (蓝线)
- ② -36 - -75 VDC (棕线)
- ③ Chassis Ground (黄线)
- ④ 12 VDC PSU (从开放式机架后方的母线取电)

警告： 使用 UL/IEC/EN60950-1 认证的电源连接 DC converter。使用 #14 AWG (用于 36 VDC 到 75 VDC PSU) 或 #10 AWG (用于 12 VDC PSU) 线连接到 DC PSU。

6. 确认交换机的运转情况

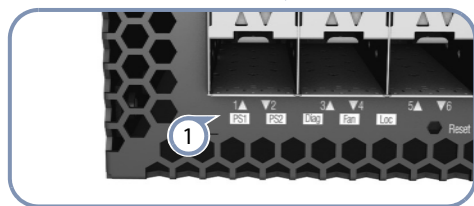

- ① 透过检查系统 LED，确认交换机的基本运转情况。如运转正常，PSU1/PSU2 和风扇 LED 会亮起绿灯。

7. 执行初次系统启动

- ① 如果网络操作系统 (NOS) 安装程序位于网络服务器中，应首先使用 5、5e 类或以上双绞线将 RJ-45 管理 (Mgmt) 端口连接到网络。(NOS 安装程序位于相连的存储装置中时不需要。)

- ② 启动交换机。等待 ONIE 软件找到和执行 NOS 安装程序，然后等待安装程序加载 NOS 软件映像。以后交换机启动时将跳过 ONIE 而直接运行 NOS 软件。

注意： 有关 ONIE 软件位置选项和设置的详细信息，请参见 NOS 安装程序和 NOS 文档。

8. 连接网线

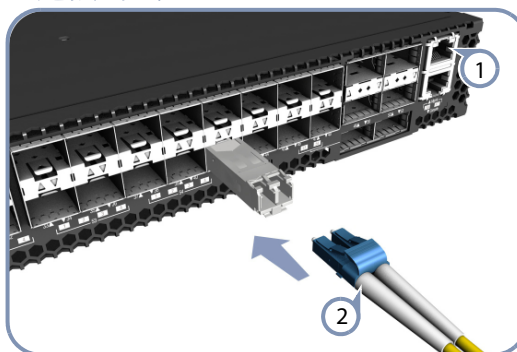

- ① 对于 RJ-45 管理端口，请连接 100-ohm 类别 5、5e 或以上的双绞线。
- ② 将 DAC 缆线连接至 SFP+/QSFP+ 插槽。也可先安装好 SFP+/QSFP+ 收发器，然后将光纤连接至收发器端口上。可使用以下收发器：
 - ◆ 40GBASE-CR4
 - ◆ 40GBASE-SR4
 - ◆ 10GBASE-CR
 - ◆ 10GBASE-SR (ET5402-SR)
 - ◆ 100GBASE-SX (ET4201-SX)
 - ◆ 100GBASE-LX (ET4201-LX)

注意： 完成连接后，请检查端口状态 LED，以确保已正常连接。

9. 查看产品标签

(仅 AS5712-54X/AS5812-54X 交换机)

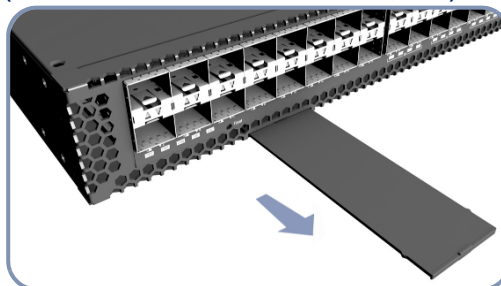

- ① 交换机产品标签位于前面板左侧 SFP+ 端口 7 - 12 的下方。拉出标签可以查看产品信息。

硬件规格

交换机机箱

尺寸 (宽 x 深 x 高)	438.4 x 473 x 43.4 mm (17.26 x 18.62 x 1.71 英寸)
重量	AS5710-54X / AS5712-54X: 8.87 kg (19.56 磅), 含附带的两个 PSU AS5812-54X: 8.95 kg (19.73 磅), 含附带的两个 PSU s
温度	运转时: 0° C 至 40° C (32° F 至 104° F) 储存时: -40° C 至 70° C (-40° F 至 158° F)
湿度	运转时: 5% 至 95% (非冷凝)
功率消耗	最大 282 瓦

AC PSU

额定功率	100 – 240 VAC, 50-60 Hz, 400 瓦
AC 输入	100 – 240 VAC, 50-60 Hz, 6 – 3 A
DC 输出	5 VSB @ 3 A, 12 VDC @ 33 A

48 VDC PSU

额定功率	48 VDC, 400 瓦
DC 输入	36 – 75 VDC, 最大 16 A
DC 输出	5 VDC @ 0.5 A, 12 VDC @ 33 A

12 VDC PSU (PSU-12V-650)

DC 输入	12 VDC (从开放式机架后方的母线取电)
-------	------------------------

法规符合性

排放	EN 55032:2012+AC:2013, Class A AS/NZS CISPR 32:2013, Class A CISPR 32:2012, Class A EN 61000-3-2:2014, Class A EN 61000-3-3:2013 FCC Class A VCCI Class A CE Mark KCC (仅限 AS5710-54X/AS5712-54X) CCC GB 9254-2008, Class A BSMI EMI Standard CNS 13438:2006 (仅限 AS5712-54X/AS5812-54X)
抗扰性	EN 55024:2010+A1:2015 IEC 61000-4-2:2008 ED. 2.0 IEC 61000-4-3:2010 ED. 3.2 IEC 61000-4-4:2012 ED. 3.0 IEC 61000-4-5:2014 ED. 2.0 IEC 61000-4-6:2013 ED. 4.0 IEC 61000-4-8:2009 ED. 2.0 IEC 61000-4-11:2004 ED. 2.0
安全	UL (CAN/CSA C22.2 No. 60950-1 & UL60950-1) CB (IEC/EN60950-1) CCC GB4943.1-2011 BSMI Safety Standard CNS14336-1
台湾 RoHS	CNS 15663

快速入門指南

54 埠 10G/40G 乙太網路交換機

AS5710-54X | AS5712-54X | AS5812-54X

Edge-core

1. 拆開交換器包裝並檢查內容物

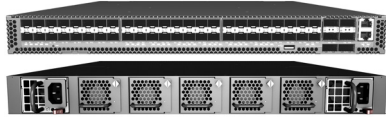

AS5710-54X,
AS5712-54X 或
AS5812-54X



前柱托架 x2、後柱托架附可調固定片 x2、托架螺絲 x20、後托架固定片位置 - 定位螺絲 x2



電源線 (僅隨附於 AC PSU)



接地線 (僅隨附於 DC PSU)



控制電纜 - RJ45 轉 DB-9



DC 電源線 (僅隨附於 48 VDC PSU)



文件 - 快速入門指南 (本文件) 及 安全性與法規資訊



警告：為了可以更安全的使用與安裝機台，請務必使用 AS5710-54X, AS5712-54X, AS5812-54X 隨貨附贈的配件，避免導致設備損壞或其他風險產生。使用未經批准的配件造成的任何損壞，均不在保修範圍內。



注意：交換器包含插入式電源供應器以及風扇托盤模組。所有後部安裝之模組氣流方向，必須一致。意即，如果安裝的電源供應器有從前至後的氣流方向 (F2B)，則所有安裝的風扇托盤模組也必須為前至後的氣流方向 (F2B)。



說明：交換器有預載之開放網路安裝程式環境 (ONIE) 軟體，但未預載交換器軟體映像檔。有關其他相容交換器軟體請參閱 www.edge-core.com 網站說明。



說明：本文件使用的交換器圖片僅供舉例說明，不一定與您的交換器外觀完全一致。

2. 安裝交換器

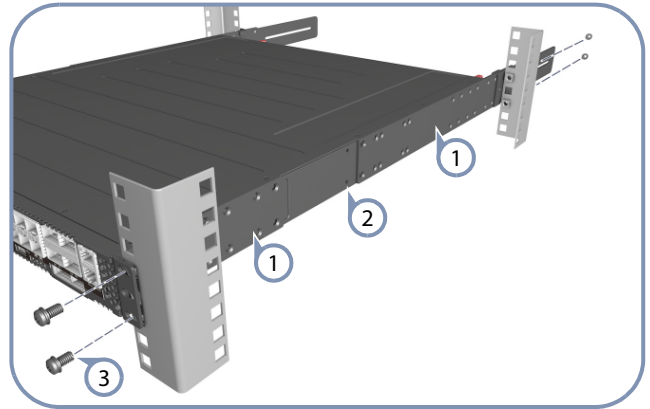

- 1 利用四個所附之托架螺絲，將前柱和後柱托架安裝在交換器上。
- 2 額外使用兩個螺絲，將後柱托架各別固定在交換器側邊中間處。
- 3 使用隨機櫃提供的螺絲及籠罩螺帽，將交換器固定在機櫃上。

3. 調整後柱托架固定片

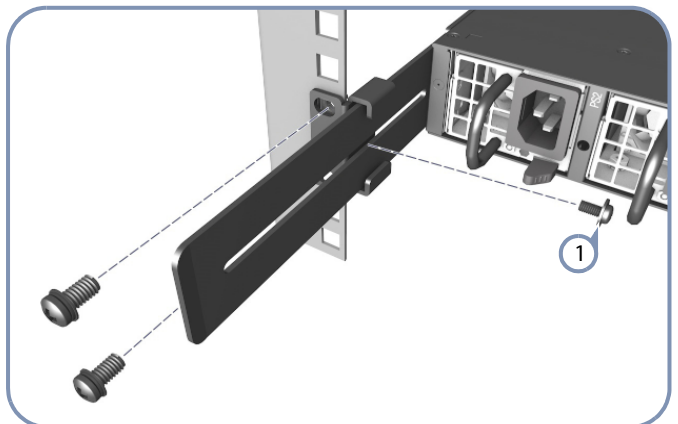

- 1 利用所附的定位螺絲，鎖緊後柱托架固定片位置。亦可調整後柱托架固定片，以安裝在深度為 56 cm 至 75 cm 不等之機櫃上。

4. 對交換器實施接地

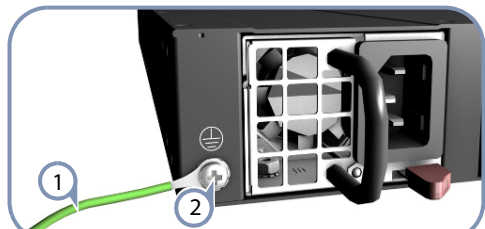

- 請確保對機架正確實施接地，並確保符合 ETSI ETS 300 253。請確認機架上的接地點的電氣導通狀態良好（確保沒有油漆或絕緣表面處理）。
- 將 14 號 AWG 接地線連接至交換器背面面板上的接地點上。然後將接地線的另一端連接至機架的接地。關於如何連接 12 VDC PSU 至開放式機架連接器，請參閱 Edgecore ORSA-1U Open Rack Tray Set 安裝手冊。

注意：在斷開所有電源連接前，切勿斷開接地。

5. 連接電源

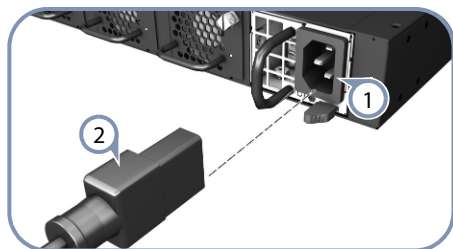

- 在交換器上安裝 1 個或 2 個 AC 或 DC 電源模組。本交換器可使用最多 2 個 PSU，且 PSU 的氣流方向必須與安裝的風扇框相同。
- 將外部 AC 或 DC 電源連接至模組。

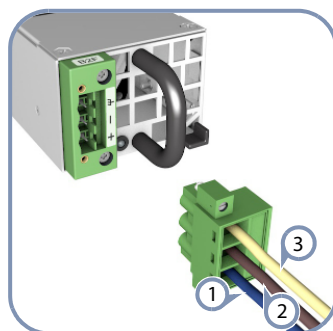

1 36 – 75 VDC Return (藍線)

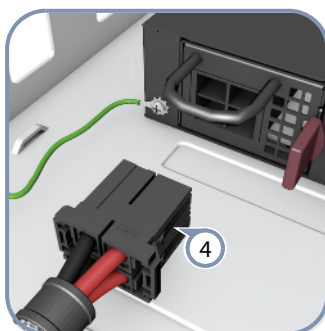

3 Chassis Ground (黃線)
4 12 VDC PSU (連接開放式機架後方的連接器)

2 -36 – -75 VDC (棕線)

注意：在 DC Converter 的前端必須使用 UL/IEC/EN 60950-1 認證的電源供應器。連接 DC PSU。使用 #14 AWG 線（適用於 36 VDC 至 75 VDC PSU）或 #10 AWG 線（適用於 12 VDC PSU）連接至 DC PSU。

6. 確認交換器操作

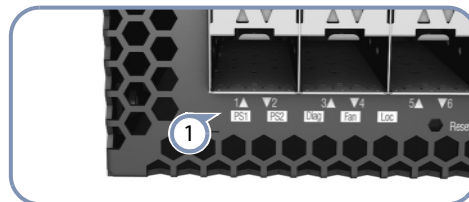

- 透過檢查系統 LED，確認交換器的基本運轉情況。如運轉正常，PSU1/PSU2 和風扇 LED 會亮起綠燈。

7. 執行初次系統啟動

- 若網路作業系統 (NOS) 安裝程式位於網路伺服器，先使用 5-ohm 第 5 類、5e 類或更優之雙絞線電纜，連接 RJ-45 管理 (Mgmt) 埠至網路。(若 NOS 安裝程式位於所附儲存設備中，則不需要。)
- 啟動交換器。等待 ONIE 軟體找尋並執行 NOS 安裝程式，並等待安裝程式載入 NOS 軟體映像檔。之後交換器啟動時，會跳過 ONIE，直接運行 NOS 軟體。

說明：關於詳細軟體選項及 ONIE 設定說明，請參閱網路作業系統 (NOS) 安裝程式及 NOS 文件。

8. 連接網路線

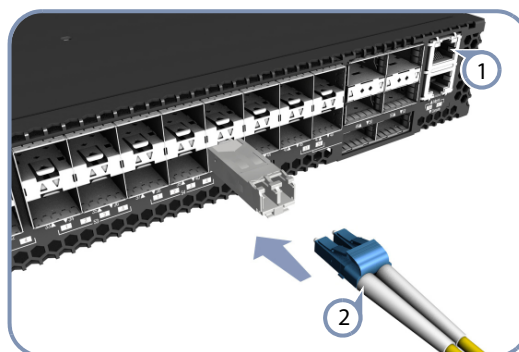

- 對於 RJ-45 管理埠，請連接 100-ohm 類別 5、5e 或以上的雙絞線。
- 連接光纖電纜至收發器連接埠。或直接將 DAC 線連接至 SFP+/QSFP+ 插槽。
支援以下收發器：
 - ◆ 40GBASE-CR4
 - ◆ 40GBASE-SR4
 - ◆ 10GBASE-CR
 - ◆ 10GBASE-SR (ET5402-SR)
 - ◆ 1000BASE-SX (ET4201-SX)
 - ◆ 1000BASE-LX (ET4201-LX)

說明：完成連接後，請檢查埠狀態 LED，以確保正常連接。

9. 檢視產品標籤

(僅 AS5712-54X/AS5812-54X 交換器)

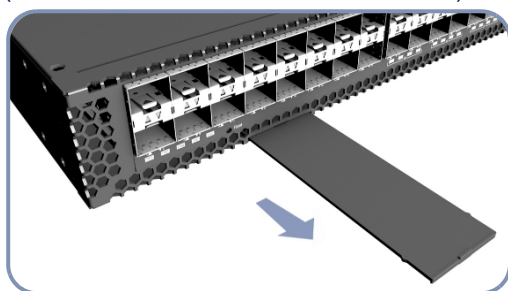

- ① 交換器產品標籤，位於 SFP+ 連接埠 7-12 下方、前方面板左側。拉出標籤即可檢視產品資訊。

硬體規格

交換器機箱

尺寸 (WxDxH)	438.4 x 473 x 43.4 mm (17.26 x 18.62 x 1.71 英寸)
重量	AS5710-54X / AS5712-54X: 8.87 kg (19.56 lb) · 含兩個安裝之 PSU AS5812-54X: 8.95 kg (19.73 lb) · 含兩個安裝之 PSU
溫度	操作：0° C 至 40° C (32° F 至 104° F) 儲存：-40° C 至 70° C (-40° F 至 158° F)
濕度	操作：5% 至 95% (無冷凝)
消耗功率	最大 282 瓦

AC PSU

額定功率	100–240 VAC · 50-60 Hz · 400 瓦
AC 輸入	100–240 VAC, 50-60 Hz, 6–3 A
DC 輸出	5 VSB @ 3 A, 12 VDC @ 33 A

48 VDC PSU

額定功率	48 VDC · 400 瓦
DC 輸入	36–75 VDC · 最大 16 A
DC 輸出	5 VDC @ 0.5 A, 12 VDC @ 33 A

12 VDC PSU (PSU-12V-650)

DC 輸入	12 VDC (從開放式機架後方的母線取電)
-------	--------------------------

法規符合性

排放	EN 55032:2012+AC:2013, Class A AS/NZS CISPR 32:2013, Class A CISPR 32:2012, Class A EN 61000-3-2:2014, Class A EN 61000-3-3:2013 FCC Class A VCCI Class A CE Mark KCC (僅限 AS5710-54X/AS5712-54X) CCC GB 9254-2008, Class A BSMI EMI Standard CNS 13438:2006 (僅限 AS5712-54X/AS5812-54X)
電磁耐受性	EN 55024:2010+A1:2015 IEC 61000-4-2:2008 ED. 2.0 IEC 61000-4-3:2010 ED. 3.2 IEC 61000-4-4:2012 ED. 3.0 IEC 61000-4-5:2014 ED. 2.0 IEC 61000-4-6:2013 ED. 4.0 IEC 61000-4-8:2009 ED. 2.0 IEC 61000-4-11:2004 ED. 2.0
安全性	UL (CAN/CSA C22.2 No. 60950-1 & UL60950-1) CB (IEC/EN60950-1) CCC GB4943.1-2011 BSMI Safety Standard CNS14336-1
台灣 RoHS	CNS15663